



CASE HISTORIES

Supplement No. 12
December, 1972

Companion journal to the
FLYING SAUCER REVIEW

Editor CHARLES BOWEN
Assistant Editor EILEEN BUCKLE
Consultants
GORDON CREIGHTON,
MA, FRAI, FRGS, FRAS
C. MAXWELL CADE,
AInstP, FRAS, AFRAeS,
CEng, FIEE, FIERE
BERNARD E. FINCH,
MRCS, LRCP, DCh, FBIS
CHARLES H. GIBBS-SMITH,
MA, FMA, Hon Companion
RAeS, FRSA
R. H. B. WINDER,
BSc, CEng, FIMechE
PERCY HENNEL
FIBP
Overseas
AIMÉ MICHEL
BERTHOLD E. SCHWARZ,
MD
Artwork
TERENCE COLLINS

CONTENTS

A Possible Landing at Matadepera	<i>José Maria Casas-Huguet</i>	1
UFO Landing Reported in Yugoslavia	<i>Milos Krmelj</i>	.. 4
UFO Photographed over Okinawa	<i>Jun-Ichi Takanashi</i>	.. 6
A French Landing in 1944	<i>F. Lagarde</i> 8
Preliminary Catalogue of Type 1 Cases in Argentina	<i>Oscar A. Uriondo</i> 9
UFO Occupant at Riachuelo, Chile	 12
Readers' Reports	 13
The Investigations of General Uchoa in Brazil—Part 1	<i>Gordon Creighton</i> 15
The Sighting at Ghost Pine Mine	<i>W. K. Allan</i> 16

1972

© Flying Saucer Review
Case Histories

Contributions appearing in this magazine do not necessarily reflect its policy and are published without prejudice

By Annual Subscription with effect from Supplement 11, U.K. and overseas £1.44 or U.S.A. and Canada \$3.80 (bank exchange commission on dollar cheques is catered for in this amount) or foreign currency equivalents. These amounts include postage by surface mail. Airmail per annum extra for U.S.A., Canada, S. Africa, Argentina, Brazil, etc., £1.10 (\$2.75); Australia, New Zealand, etc., £1.40; Middle East £0.80. Single copies 24p each (65c each)

Please address all letters to: *The Editor, FSR Case Histories, 21 Cecil Court, Charing Cross Road, London WC2N 4HB, England*

Subscriptions (payable to "FSR Publications Ltd.") to: *21 Cecil Court, Charing Cross Road, London WC2N 4HB, England*
Telephone: 01-639 0784

FLYING
SAUCER
REVIEW



CASE HISTORIES

TWENTY-FOUR PENCE

SUPPLEMENT 12

DECEMBER 1972

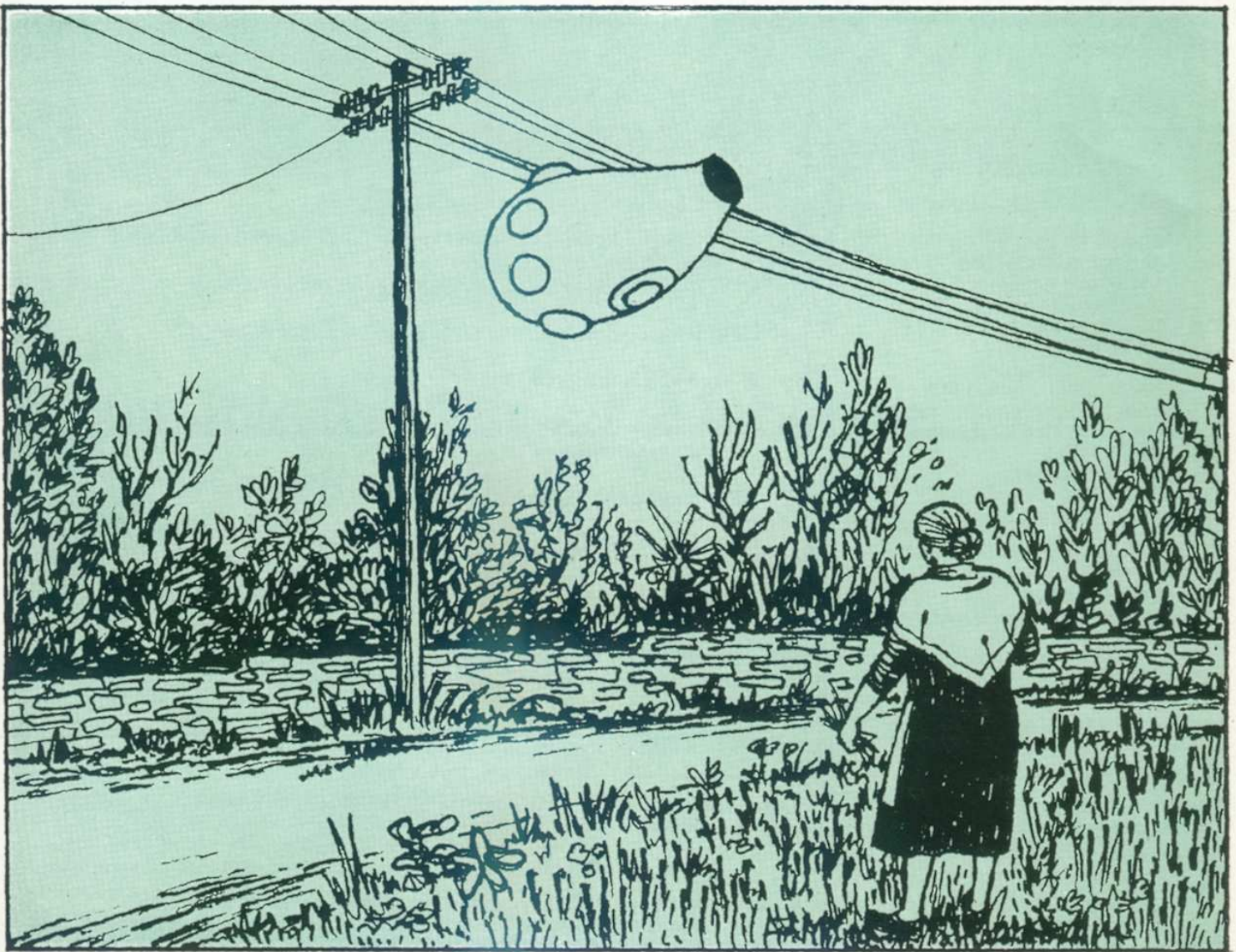

POSSIBLE LANDING AT MATADEPERA

A recent report from Spain

see page 1

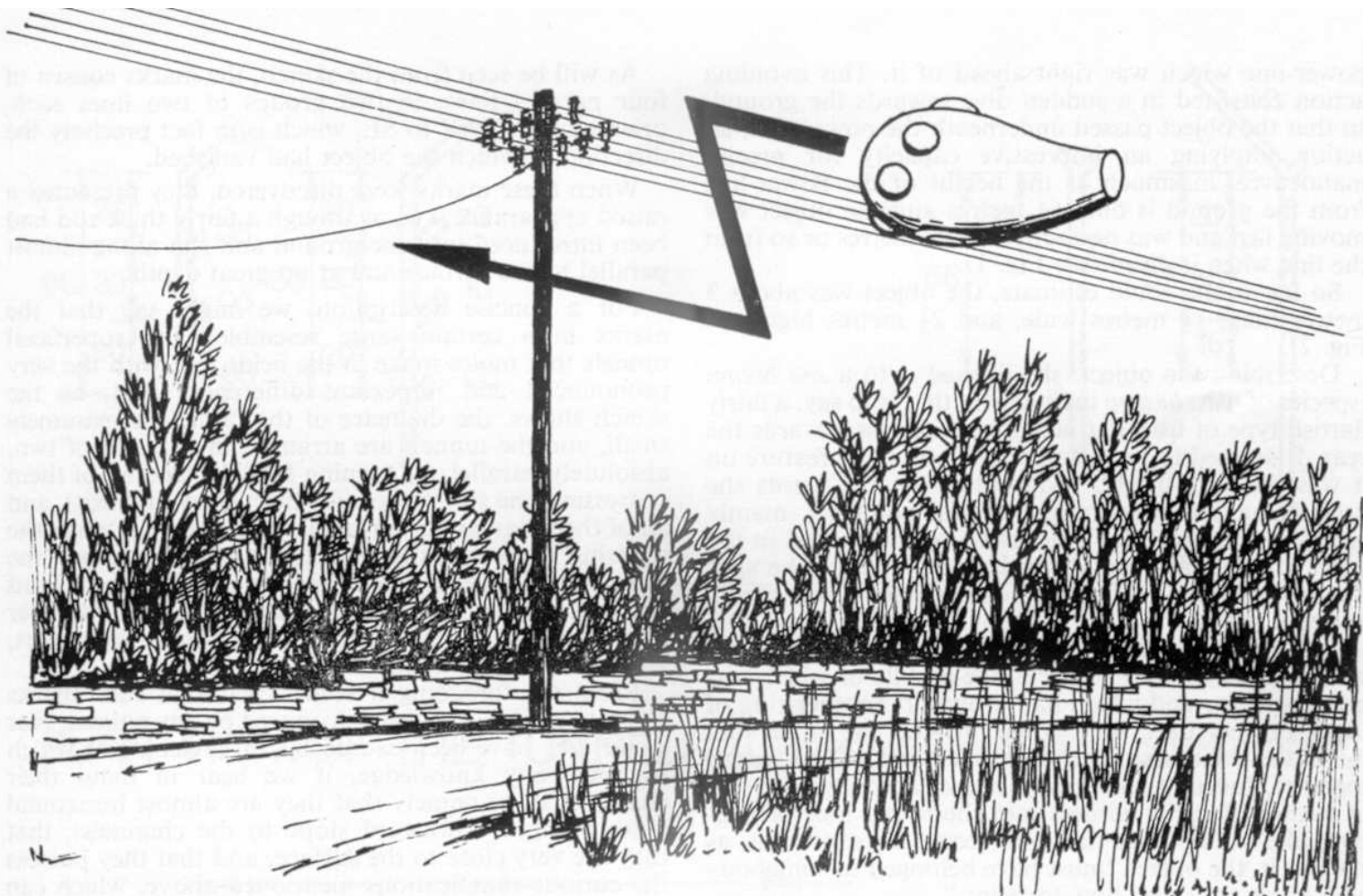

A possible landing at Matadepera

José Maria Casas-Huguet

WE have selected the following case from our files as we think it will be of interest to our readers, notwithstanding the fact that an account of it has already appeared in the Barcelona magazine *Algo*, No. 155 (June 1-15, 1970).

The event occurred in the closing days of January 1969 (perhaps on the 29th) at Matadepera, near Barcelona. The only witness was an old lady of 80, who however is possessed of magnificent and most enviable health and strength, and whose eyesight, although she does wear glasses, can as we have been able to confirm for ourselves, be described as entirely normal. We can likewise affirm that she is sound in all her other senses, and that on the various occasions when we have interviewed her she has displayed a liveliness and a mental agility that are right outside the range of what is usually found in persons of so advanced an age.

This spirited and charming old lady, whose name we are asked not to divulge (we have given her the pseudonym of Doña Antonia Soler Rius in our earlier, brief version of this report in *Stendek*) frequently goes for a stroll on the hillsides in order to get a little exercise, to gather herbs, and to escape from the monotonous and cramped confines of her house. On the day in question, she went out at about 10.00 a.m. and headed, as usual, for the outskirts of the town.

* * * * *

Señor Casas-Huguet is the President of the Spanish investigation group C.E.I. (Centro de Estudios Interplanetarios) established in Barcelona by Antonio Ribera and colleagues, and publishers of the excellent Spanish journal *Stendek*,* now in its third year of existence. The present article, translated by Gordon Creighton, comes from *Stendek* for March 1972 (Year III, No. 8) and appears with the kind permission of their Editor, Señor Josep Serra, and of the Directing Council.—EDITOR.

It was a very fine day, sunny, with a cloudless sky. The eyewitness was standing by the verge of the road, plucking herbs, when she suddenly heard a loud noise which struck her as most strange and unwonted for such a place. She describes the sound as like that made by a car passing close by at high speed. She at once straightened up and looked around to see what was causing the sound and beheld, coming from among the trees to the right of her, and travelling on a slightly ascending oblique trajectory, "a curious flying object."

As she watched, the object changed course extremely quickly and abruptly so as to avoid hitting a 5,000-volt

* *Stendek* address: STENDEKCEI, Apartado 282, Barcelona, Spain.

power-line which was right ahead of it. This avoiding action consisted in a sudden dive towards the ground, so that the object passed underneath the power-line, an action implying an impressive capacity for precise manoeuvre, inasmuch as the height of the power-line from the ground is only $6\frac{1}{2}$ metres and the object was moving fast and was no more than 20 metres or so from the line when it dived (see Fig. 1).

So far as she could estimate, the object was about 3 metres long, $1\frac{1}{2}$ metres wide, and $2\frac{1}{2}$ metres high (see Fig. 2).

Describing the object, she likened it to a *sea bream* (species of fish: *besugo* in Spanish), that is to say, a fairly flattish type of fish that tapers in thickness towards the rear. It seemed to be metallic, and a notable feature on it was the very bright, vivid colouring, the words she used being that the thing "was all coloured, mainly green and yellow," the colours being distributed in the form of spots and leaf-shaped marks. Where the spot was yellow, then the leaf or zone around it was green, and vice versa.

On the belly or under part of the object she could see very distinctly a sort of circle, the middle of which was orange-yellow and which had around it another ring of black or very dark blue. Then, around the latter still, there was a circular area with green and yellow mixed together, forming, as already stated, a very pretty sort of pattern that the witness said she found most attractive, like nothing she had ever seen before, so that, as she put it, the object "must have belonged to somebody who knew very well how to paint."

On the front part of the object there were rounded or spherical protuberances. She saw no portholes or windows or doors. In other words, the surface seemed to her to be smooth and uniform.

Figure 1 shows how, in its manoeuvre to avoid hitting the power-line, the object dropped abruptly and shot through a gap, approximately 6 metres high and 4 metres wide, between the post of the power-line on the one hand and a small pine tree, not very thick and less high than the cable, on the other hand.

Once past the obstacle of the power-line, the object began to rise again gently and rapidly, in the way that an aircraft climbs, and made off at good speed and at no great height, over the low houses and the pine trees, towards Terrassa, a town some 6 km. from Matadepera.

But that is not the end of the affair, and what follows may be of great significance.

The first report of this case came to us from Señor Joan Fonolleda Prat, our representative at Sabadell. Sr. Fonolleda asked the old lady to accompany him to the place so that he could make an inspection and look for possible marks or other evidence of a landing. The result was that, close to where the old lady had stood when she had the sighting (the actual distance was 30-40 metres), he found some curious marks on the ground.

As soon as the report about these marks reached us at C.E.I. a group of our members set off to examine the spot.

Figure 3 shows the nature of the marks.² Since it has been quite impossible to find any conventional explanation for such marks, they constitute the only piece of evidence we have that a UFO had [possibly] landed at that place.

As will be seen from the sketch, the marks consist of four parallel lines, in two groups of two lines each, oriented from NW to SE, which is in fact precisely the direction in which the object had vanished.

When these marks were discovered, they presented a raised appearance, i.e., as though a fairly thick rod had been introduced into the ground and run along almost parallel to the surface and at no great depth.

For a concise description, we might say that the marks in a certain sense resembled the superficial tunnels that moles make in the fields, but with the very pronounced and important differences that, as the sketch shows, the diameter of the tunnels is extremely small, and the tunnels are arranged in two sets of two, absolutely parallel, all running NW-SE, and all of them possessing one sole orifice (for both entry and exit), and all of them having this distinctive feature that, when the covering layer of earth was removed from above the little channels, caused by the introduction of some hard body into the ground, there became apparent a number of curious equidistant lateral ramifications, very short, and of very small diameter.

From the foregoing it seems clear that such marks cannot possibly have been produced by any animal. Nor could they have been caused by any machine of which we have any knowledge, if we bear in mind their characteristics: namely that they are almost horizontal (with a slight downward slope to the channels), that they are very close to the surface, and that they possess the curious ramifications mentioned above, which can be seen clearly from Fig. 3.

It is also worth mentioning that inside these small channels, in the soil, it could be seen quite clearly that the earth had been compressed against their walls. This adds plausibility to the thesis that some hard, rectilinear, narrow object had been introduced into the ground under great pressure.

Of the two sets of marks that were found, the left-hand pair were a lot more pronounced than the other pair. (There were also four more marks, at a distance of some nine to ten metres, but as these were very indistinct and ill-defined, we prefer not to make any statement about them.)

When we had removed the surface soil covering the two pairs of more clearly defined marks, in order to examine the interior of the small channels—which seemed not to contain anything—we made a plaster cast of one of the marks, although, as was only to be expected, it did not turn out perfect and was considerably bigger than the original. We also made a model, in special soft clay, of the object seen by the eyewitness and as described by her to us.

Finally we might add that the lady experienced no shock of any kind, nor any other type of negative after-effects from her experience. On the contrary indeed. She was extremely pleased and satisfied at having seen "something so pretty." She had never previously heard anybody speak of UFOs. On the other hand, as she assured us, she knows very well indeed what an aeroplane and a helicopter look like, and she can distinguish between them. She had some difficulty in pronouncing the word helicopter, which is a new term to her and remote from her mentality and her degree of education,

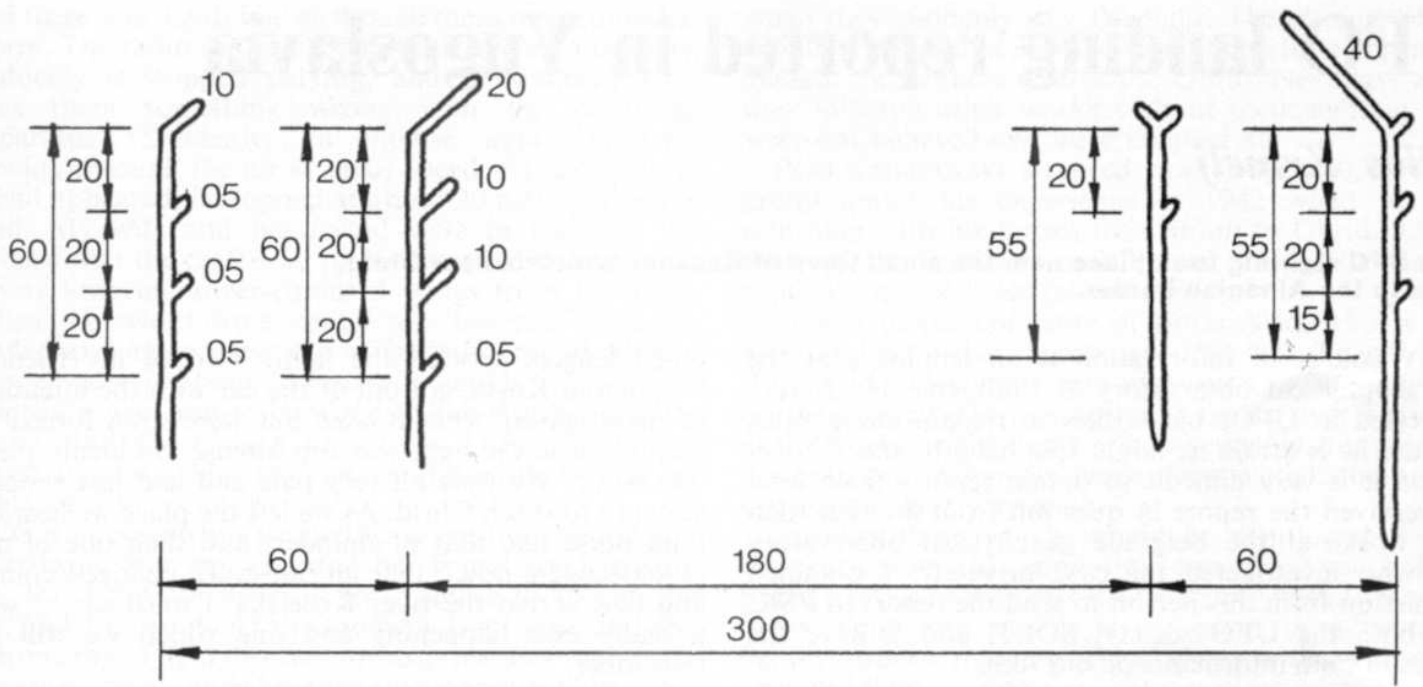

PLAN VIEW OF THE TUNNELS (ALL DIMENSIONS GIVEN IN CENTIMETRES).

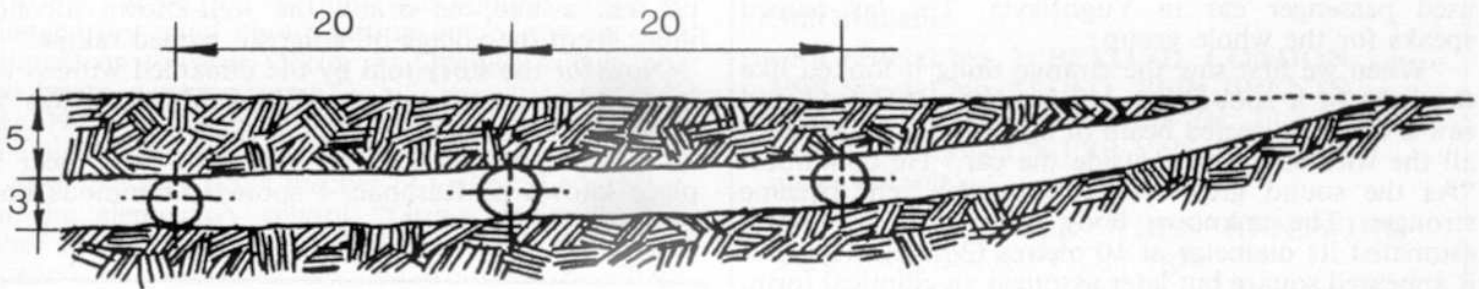

SECTIONAL VIEW OF THE TUNNELS

but she says she has seen helicopters a few times on her TV set.

She assures us that what she saw was something totally and absolutely unknown to her, and she is unable to say what it could have been, which is easy to understand since, in similar circumstances, we would find ourselves in the same position. One curious point is that she insisted that what she had seen must have been something "from abroad", hoping thereby to indicate no doubt the degree of strangeness and surprise that the episode held for her. And as we know well, in past times, and indeed even today still, there are folk for whom the word "foreign" is a synonym for the

remote, the strange, and the surprising . . . something out of the way and rare.

Notes by Gordon Creighton

- ¹ Readers are reminded that Barcelona lies in Cataluña and that the mother-tongue of the members of C.E.I. is not Castillian Spanish, but *Catalan*, a proud, separate, and ancient member of the Latin family of languages. *Joan* in Catalan is the equivalent of the Castillian *Juan*, and refers therefore to a man and not to a woman as English-speaking readers might have thought.
- ² While it is not suggested that the markings are identical, it might be well to study them in conjunction with the equally mysterious markings found at Marliens in France (see FSR for September/October 1967).

We rely on our readers' recommendations, so . . .
TELL YOUR FRIENDS ABOUT *FLYING SAUCER*
REVIEW* and *FSR CASE HISTORIES

UFO landing reported in Yugoslavia

Milos Krmelj

This UFO sighting took place near the small town of Rasanac which is near Ohrid, close to the Albanian border.

MY source of information is an employee at the geophysical observatory at Ljubljana. He is very interested in UFOs but wishes to remain anonymous because he is afraid he might lose his job, and for this reason it is very difficult to obtain reports from him. He received the report in question from another man who works at the Belgrade geophysical observatory and who investigated the case privately. I obtained permission from this person to send the report to FSR, and both the UFO society, SOLT, and I, have the names of both informants on our files.

The occurrence took place at 1.00 a.m. on August 2, 1971. The principal witness wishes to be unnamed, but we have his name on file. Other witnesses are members of the beat band "Dubrovacki Trubaduri," namely Kosta Verus, Stojan Klatovski and Milorad Dusanovic. They had been travelling in a Fiat 750, the most widely used passenger car in Yugoslavia. The last-named speaks for the whole group:

"When we first saw the strange thing it looked like the light of a spot-light; we also heard a sound and saw a strong, directed beam of light." (At this moment all the witnesses were outside the car.) He continues: "As the sound grew stronger, so the light became stronger. The unknown body hovered in the air. I estimated its diameter at 10 metres (33 feet). At first it appeared square but later assumed an elliptical form. The light grew even stronger. It was stronger on the edge than in the middle. Because of the configuration of the terrain we were unable to see whether the object actually landed or not, but we clearly saw rays coming through the forest trees. We were certain the object was either in or behind the forest which is near the Ohrid-Bitolj road, lying no more than 40 metres (125 feet) back from the road-side.

"It was really interesting to watch that unusual object. First we saw it as a square, and it gradually reshaped to become an elliptical body. It then projected a very strong beam of light. Even I was determined to go to the place where the strange thing hovered or landed, hoping to see what it was, but I was unable to do so owing to the intensity of the light. I had not believed my friend who told me that only the day before he had met with an unusual object at that very spot.

"Just before we encountered the strange light, when we had reached the small town of Rasanac, I had seen a small green frog jump from somewhere onto the steering wheel. Only a moment later, someone shouted to me to take care as a scorpion had appeared on the door. When I was a child I was afraid of that small creature because it is very poisonous. At that moment I stopped the car and it was then that one of the

co-passengers spotted the light. Two of my friends, Stojan and Kosta, got out of the car with the intention of investigating what it was, but were soon forced to stop because the light was too intense. Suddenly there was panic. We were all very pale and had just enough strength to reach Ohrid. As we left the place we heard a loud noise like that of thunder, and then one of my co-passengers noted that an 'air-craft' changed course and flew across the river Koselska. I must say, it was a really rare happening and one which we will all remember."

Golubinka, wife of Milorad Dusanovic, said: "I have no words to describe how Milorad looked that night when he arrived home. He simply was unable to say anything. He was so pale that I was very worried. To pull himself together, he took a bath, even though it was very late (2.00 a.m.); in the morning, as soon as he was awake, he drank the well-known alcoholic liquor from the village of Volgosti, named rakija."

Now for the story told by the unnamed witness who is an administrator of the Ohrid Museum. We will call him after his initials, Mr. N.C.

"It was about 1.00 a.m. when we came near the place known as Rasanac. I spotted a luminous body,

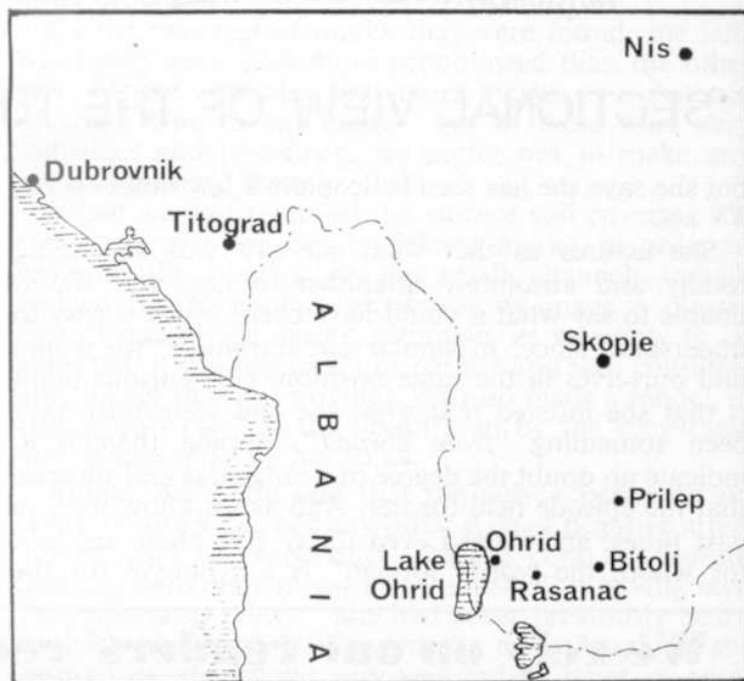

Southern Yugoslavia, showing the location of Ohrid (formerly Ochrida) and district. The lake is surrounded by mountain peaks ranging from 4,500 to more than 7,300 feet